

Corrugated Structural Plates



GEOTUO

geotuo.com | hello@geotuo.com

Applications

for drainage purposes, pedestrian and vehicular underpasses, tunnel liner, and utility tunnels

The standards to meet for corrugated steel pipes:

ASTM A761/A761M-15

standard specification for corrugated steel structural plate, zinc-coated for field-bolted pipe, pipe arches, and arches

Classification

type 1 fabricated with bolted lap seams

type 2 with bolted flange seams for corrugation 15 by 5 1/2 in. (2 or 4 flanges for tunnel liner)

Materials and Coatings

materials	coating
zinc (galvanizing) coated steel sheet	2 oz/ft ² zin coating

Corrugations

inch		mm	
pitch	depth	pitch	depth
5	1	125	25
6	2	150	50
9	2 1/2	230	64
15	5 1/2	380	140
16	6	400	150

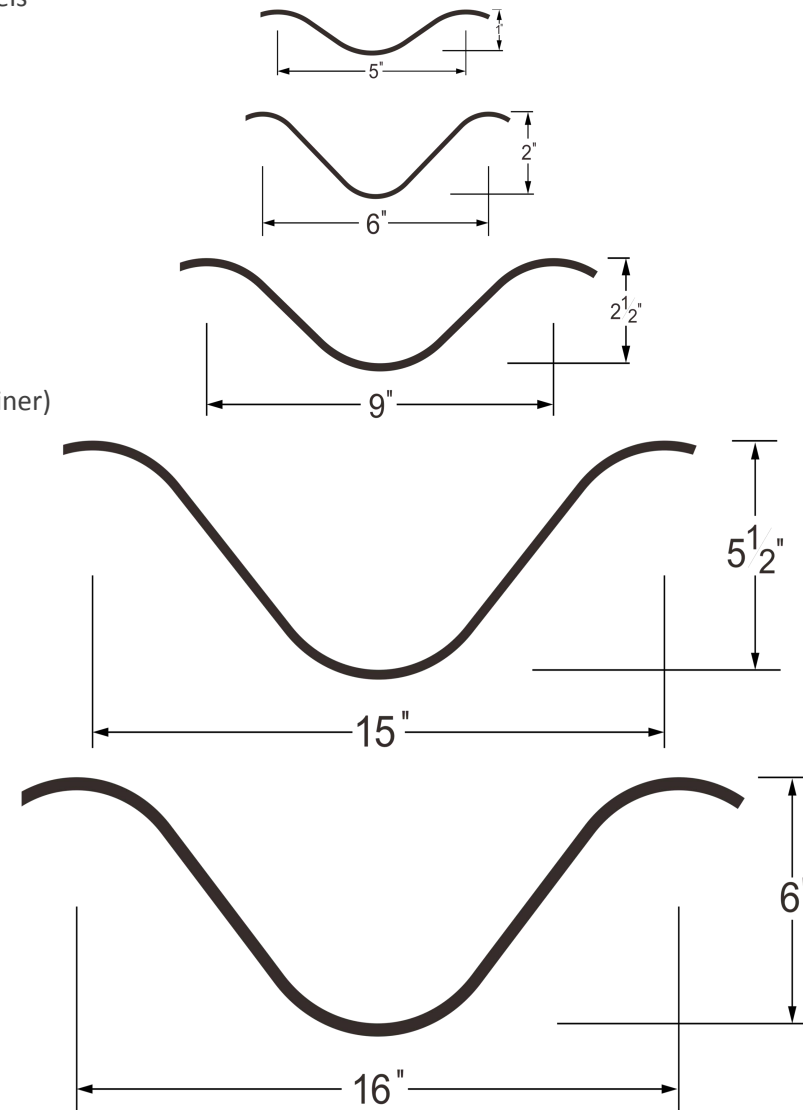

Thickness of Zinc-Coated Plates

specified thickness		Min. thickness	
in.	mm	in.	mm
0.111	2.82	0.099	2.51
0.118	3.00	0.106	2.69
0.140	3.56	0.128	3.25
0.157	3.99	0.146	3.71
0.170	4.32	0.158	4.01
0.188	4.78	0.176	4.47
0.197	5.00	0.185	4.70
0.218	5.54	0.206	5.23
0.236	5.99	0.224	5.69
0.249	6.32	0.237	6.02
0.276	7.01	0.264	6.71
0.280	7.11	0.268	6.81
0.310	7.87	0.295	7.49
0.319	8.10	0.305	7.75
0.380	9.65	0.358	9.09
0.411	10.44	0.389	9.88
0.443	11.25	0.421	10.69
0.473	12.01	0.451	11.46
0.505	12.83	0.483	12.27

Fabrication

fabricated by rolling annular corrugated mill sheets and riveting seams



annular rolling



curvature

Nestable Pipes

It's an economical transport solution to reduce shipping space for overseas supply. It worked as a fast and economical encasement for utilities lines without disruption. usually we supply flanged nestable as below shows:

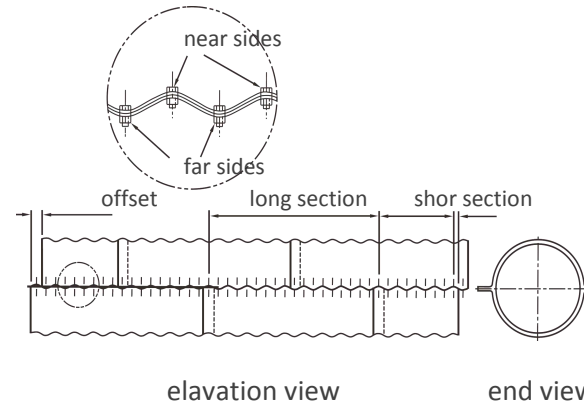

flanged nestable CSP segments

End Types

For corrugated steel pipe and pipe-arches, usually 3 types of ends shop-fabricated as follows:



cut end



skewed end



bevelled end

Structural plate corrugated round pipe

152 x 51 mm corrugation profile

Standard diameters and unit weight of assembled structure

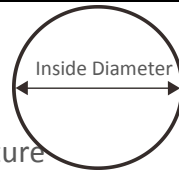

Inside Diameter mm	Periphery (Hole Spaces) N	End Area m ²	Unit Weight of Structure,kg/m				
			Specified Wall Thickness, mm				
			3.0	4.0	5.0	6.0	7.0
1500	20N	1.77	180	234	288	342	396
1660	22N	2.16	195	254	313	373	432
1810	24N	2.58	211	275	339	403	467
1970	26N	3.04	232	302	373	443	513
2120	28N	3.54	248	323	398	473	548
2280	30N	4.07	257	335	415	494	572
2430	32N	4.65	272	356	440	524	608
2590	34N	5.26	294	384	474	564	654
2740	36N	5.91	303	396	490	584	678
3050	40N	7.32	346	452	559	665	771
3360	44N	8.89	377	493	609	725	841
3670	48N	10.61	408	534	660	786	911
3990	52N	12.47	445	582	719	856	993
4300	56N	14.49	476	623	770	916	1063
4610	60N	16.66	507	663	820	977	1134
4920	64N	18.99	544	711	880	1047	1215
5230	68N	21.46	575	752	930	1108	1285
5540	72N	24.08	605	793	981	1168	1356
5850	76N	28.86	649	849	1049	1249	1449
6160	80N	29.79	680	889	1100	1309	1519
6470	84N	32.87	711	930	1150	1370	1589
6780	88N	36.1	748	978	1210	1440	1671
7090	92N	39.48	779	1019	1260	1501	1741
7400	96N	43.01	809	1060	1311	1561	1812
7710	100N	46.7	846	1108	1370	1631	1893
8020	104N	50.53	877	1149	1421	1692	1963

Structural plate corrugated pipe-arch

152 x 51 mm corrugation profile

Standard dimensions and unit weight of structure (assembled)

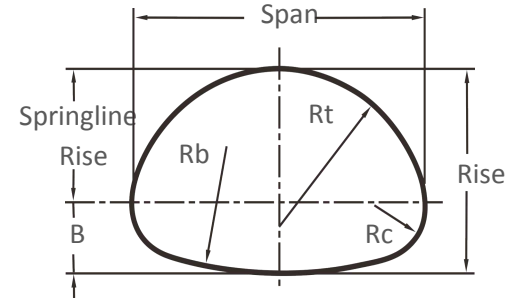

Span mm	Rise mm	End Area m ²	Layout Dimensions (to neutral axis) mm				Required N				Unit Weight of Structure, kg/m				
			B	Rt	Rc	Rb	Top	Each Corne	Bottom	Total	Specified Thickness, mm				
											3.0	4.0	5.0	6.0	7.0
2060	1520	2.49	700	1130	660	1875	9	5	5	24	210	274	339	403	467
2240	1630	2.9	680	1205	660	3370	11	5	5	26	232	302	373	443	513
2440	1750	3.36	730	1305	685	2995	12	5	6	28	248	323	398	473	548
2590	1880	3.87	735	1355	710	4420	14	5	6	30	263	343	423	503	583
2690	2080	4.49	815	1380	785	4050	16	5	6	32	285	371	458	544	630
3100	1980	4.83	790	1695	685	3850	15	5	9	34	294	384	474	564	654
3400	2010	5.28	840	2000	660	3510	15	5	11	36	316	412	508	604	700
3730	2290	6.61	900	2055	710	4045	18	5	12	40	346	452	559	665	771
3890	2690	8.29	915	1975	815	6015	23	5	11	44	384	501	618	735	852
4370	2870	9.76	1035	2265	815	4895	24	5	14	48	414	541	669	795	922
4720	3070	11.38	1015	2425	815	6430	27	5	15	52	445	582	719	856	993
5050	3330	13.24	1040	2570	840	7430	30	5	16	56	489	638	787	936	1085
5490	3530	15.1	1095	2790	840	7575	32	5	18	60	513	671	829	987	1145
5890	3710	17.07	1150	3020	840	7755	34	5	20	64	557	727	897	1067	1237
6250	3910	19.18	1120	3175	840	9630	37	5	21	68	588	767	948	1128	1308
7040	4060	22.48	1660	4090	1370	9650	31	11	21	74	653	851	1050	1248	1447
7620	4240	25.27	1750	4570	1370	9650	33	11	24	79	679	887	1096	1304	1513

Structural Plate Specification

Structural plate corrugated steel arch

152 x 51 mm corrugation profile

Standard dimensions and unit weight of structure

Span mm	Rise mm	Total Periphery (Hole Spaces) N	End Area m ²	Radius mm	Unit Weight of Structure, kg/m				
					Specified Thickness mm				
					3.0	4.0	5.0	6.0	7.0
1520	810	10N	0.98	760	87	114	141	168	195
1830	840	11N	1.16	930	95	124	154	183	213
	970	12N	1.39	910	102	134	166	198	230
2130	860	12N	1.39	1090	102	134	166	198	230
	1120	14N	1.86	1070	118	155	192	229	266
2440	1020	14N	1.86	1230	118	155	192	229	266
	1270	16N	2.42	1220	139	183	226	269	312
2740	1180	16N	2.46	1400	139	183	226	269	312
	1440	18N	3.07	1370	148	195	242	289	336
3050	1350	18N	3.16	1540	148	195	242	289	336
	1600	20N	3.81	1520	170	223	276	329	382
3350	1360	19N	3.44	1710	163	213	264	314	365
	1750	22N	4.65	1680	192	251	310	370	429
3660	1520	21N	4.18	1850	178	233	289	344	400
	1910	24N	5.48	1830	201	264	327	390	453
3960	1680	23N	5.02	2010	203	264	326	388	449
	2060	26N	6.5	1980	223	292	361	430	499
4270	1840	25N	5.95	2160	215	282	348	415	481
	2210	28N	7.43	2130	238	312	386	460	534
4570	1870	26N	6.41	2340	223	292	361	430	499
	2360	30N	8.55	2290	254	332	412	491	569
4880	2030	28N	7.43	2480	238	312	386	460	534
	2520	32N	9.75	2440	269	353	437	521	605
5180	2180	30N	8.55	2620	254	332	412	491	569
	2690	34N	11.06	2590	291	381	471	561	654
5490	2210	31N	9.01	2820	268	350	433	516	598
	2720	35N	11.71	2740	299	391	484	576	669
5790	2360	33N	10.22	2950	277	363	450	536	622
	2880	37N	13.01	2900	314	411	509	606	704
6100	2530	35N	11.52	3100	299	391	484	576	669
	3050	39N	14.59	3050	329	432	534	637	739

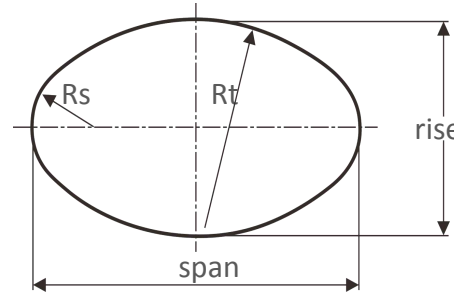
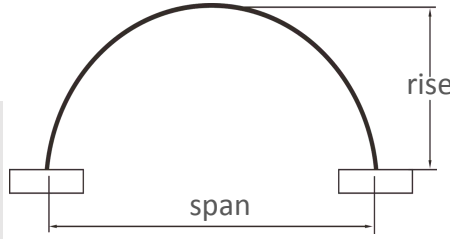

Structural plate corrugated horizontal ellipse

152 x 51 mm corrugation profile

Sizes and layout details

Span mm	Rise mm	End Area m ²	Required N			Rt Top mm	Rs Side mm
			Top or Bottom	Each Side	Total		
1630	1350	1.74	5	5	20	970	610
2130	1420	2.41	6	6	24	1710	610
2540	1630	3.24	9	5	28	1770	610
2790	1630	3.57	9	6	30	2340	640
2900	1930	4.36	11	5	32	1850	690
3200	2260	5.64	12	6	36	1990	840
3760	2260	6.62	14	6	40	2630	760
3680	2440	6.85	15	5	40	2260	760
4420	2790	9.78	15	9	48	3200	1070
4826	3429	12.86	18	9	54	2972	1283
5156	3683	14.87	18	11	58	3289	1448
5283	3531	14.59	18	11	58	3607	1359
5715	3988	18.08	18	14	64	3924	1664
6120	3960	18.77	23	10	66	3985	1370
6230	3840	18.4	24	9	66	4165	1220
6460	3910	19.42	25	9	68	4345	1220
6680	3990	20.49	26	9	70	4520	1245
7010	4290	23.15	27	10	74	4700	1370
7470	4470	25.49	29	10	78	5030	1370
7950	5540	34.25	29	15	88	5030	2085
8280	5820	37.59	30	16	92	5025	2210
8560	5210	34.28	33	12	90	5740	1650
8970	6070	42.23	33	16	98	5740	2210
9220	5460	38.55	36	12	96	6275	1650
10110	6120	47.57	39	14	106	6780	1930
10640	6500	53.29	41	15	112	7135	2085
10970	6810	57.51	42	16	116	7315	2210
11250	7800	68.25	41	21	124	7135	2920
11580	8100	72.93	42	22	128	7315	3050
11790	8510	78.31	42	24	132	7315	3325

Structural plate corrugated low profile arch

152 x 51 mm corrugation profile

Sizes and layout details

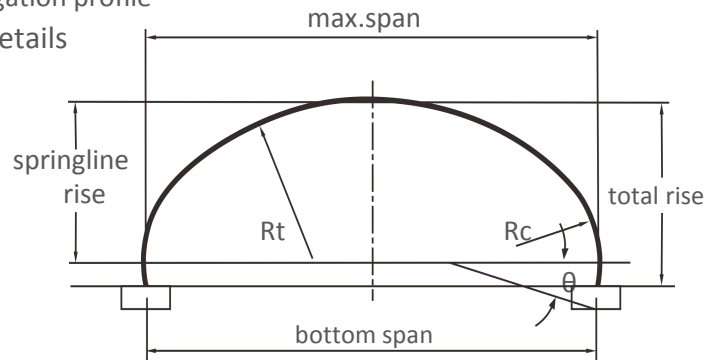

Max. Span mm	Botto m mm	Total Rise mm	End Area m ²	Required N			Rt Top mm	Rc Side mm	Springlin e Rise mm	Re-Entry Angle θ Degrees
				Top	Each Side	Total				
5920	5820	2080	9.75	23	5	33	3990	1090	1780	15.6
6120	6050	2290	11.2	23	6	35	3990	1370	1980	12.4
6550	6500	2360	12.4	25	6	37	4345	1370	2055	12.4
6780	6730	2410	13	26	6	38	4520	1370	2110	12.4
7010	6930	2440	13.6	27	6	39	4700	1370	2160	12.4
7240	7160	2490	14.3	28	6	40	4875	1370	2185	12.4
7470	7390	2540	14.9	29	6	41	5030	1370	2235	12.4
7670	7620	2570	15.6	30	6	42	5205	1370	2260	12.4
7900	7850	2620	16.3	31	6	43	5385	1370	2310	12.4
8310	8150	3280	22	31	9	49	5385	1930	2745	16.1
8760	8610	3350	23.7	33	9	51	5740	1930	2820	16.1
9420	9270	3480	26.4	36	9	54	6275	1930	2945	16.1
9630	9500	3680	28.7	36	10	56	6275	2210	3150	14
9860	9730	3730	29.6	37	10	57	6425	2210	3200	14
10080	9930	3780	30.6	38	10	58	6605	2210	3250	14
10110	9960	3610	29.2	39	9	57	6780	1930	3075	16.1
10490	10390	4040	34.1	39	11	61	6780	2490	3505	12.5
10540	10410	3680	31.1	41	9	59	7135	1930	3150	16.1
10770	10570	3730	32	42	9	60	7315	1930	3200	16.1
11560	11460	4780	44.3	41	14	69	7135	3325	4215	9.4
11790	11680	4800	45.5	42	14	70	7315	3325	4260	9.4

Structural plate corrugated high profile arch

152 x 51 mm corrugation profile

Sizes and layout details

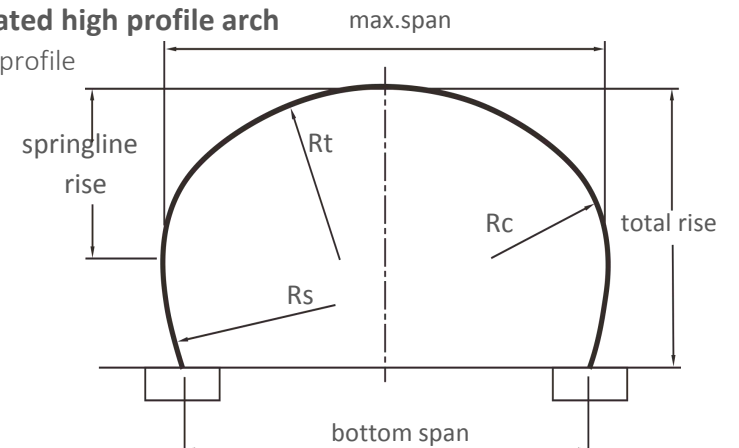

Max. Span mm	Botto m mm	Total Rise mm	End Area m ²	Required N				Rt Top mm	Rc Upper mm	Rs Lower mm	Springlin e Rise mm
				Top	Each Uppe	Each Lower	Total				
6300	5740	3680	19.85	23	6	6	47	3990	1650	3985	2200
6550	6050	3560	19.93	25	5	6	47	4345	1370	4345	2070
6780	6270	3610	20.85	26	5	6	48	4520	1370	4520	2110
7010	6530	3660	21.78	27	5	6	49	4700	1370	4700	2150
7240	6760	3680	22.71	28	5	6	50	4875	1370	4875	2190
7670	7230	3740	24.61	30	5	6	52	5205	1370	5205	2270
7870	6920	4655	31.56	30	6	9	60	5205	1650	5205	2490
8100	7190	4650	32.78	31	6	9	61	5385	1650	5385	2520
8560	7500	5020	36.92	33	6	10	65	5740	1650	5740	2610
8590	7750	4630	34.09	34	5	9	62	5920	1370	5920	2440
9220	8420	4920	39	36	6	9	66	6275	1650	6275	2730
9450	8670	4970	40.25	37	6	9	67	6425	1650	6425	2770
9680	8740	5260	43.55	38	6	10	70	6605	1650	6605	2810
9910	8990	5280	44.91	39	6	10	71	6780	1650	6780	2850
10360	9500	5380	47.67	41	6	10	73	7135	1650	7135	2930
10360	9140	5830	51.86	41	6	12	77	7135	1650	7135	2930
10570	9730	5440	49.07	42	6	10	74	7315	1650	7315	2980
10590	9390	5870	53.39	42	6	12	78	7315	1650	7315	2980
11350	10130	6910	67.08	41	11	12	87	7135	3050	7135	4000
11580	10390	6930	68.86	42	11	12	88	7315	3050	7315	4000

Deep corrugated structural plate round pipe

Type I: 381 x 140 mm corrugation profile

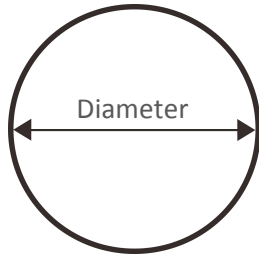

Diameter mm	End Area m ²	Total S
8450	57.2	66
8790	60.7	68
9040	64.2	70
9320	68.3	72
9580	72	74
9830	75.9	76
10080	79.9	78
10340	84	80
10620	88.5	82
10870	92.8	84
11130	97.2	86
11380	101.7	88
11630	106.3	90
12170	116.3	94
12680	126.3	98
13180	136.5	102
13720	147.8	106
14220	158.9	110
14760	171.1	114
15270	183	118
15770	195.4	122

Deep corrugated structural plate half around pipe arch

Type I: 381 x 140 mm corrugation profile

Size and layout details

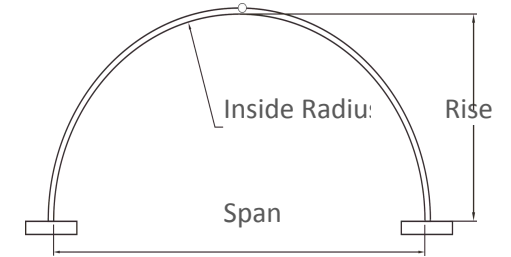

Span, mm	Rise, mm	Periphery (Hole Spaces), S	End Area m ²	Radius mm
6990	3495	27	19.19	3495
7250	3625	28	20.64	3625
7510	3755	29	22.14	3755
7640	3820	30	23.7	3885
8030	4015	31	25.29	4015
8290	4140	32	26.95	4145
8550	4270	33	28.66	4275
8800	4400	34	30.42	4400
9060	4530	35	32.24	4530
9320	4660	36	34.1	4660
9580	4790	37	36.02	4790
9840	4920	38	38	4920
10100	5045	39	40.02	5050
10360	5175	40	42.1	5180
10620	5305	41	44.23	5310
10870	5435	42	46.41	5435
11130	5565	43	48.65	5565
11390	5695	44	50.94	5695
11650	5825	45	53.28	5825
11910	5955	46	55.67	5955
12170	6080	47	58.12	6085

Multi-radius deep corrugated structural plate arches

Type I: 381 x 140 mm corrugation profile

Size and layout details

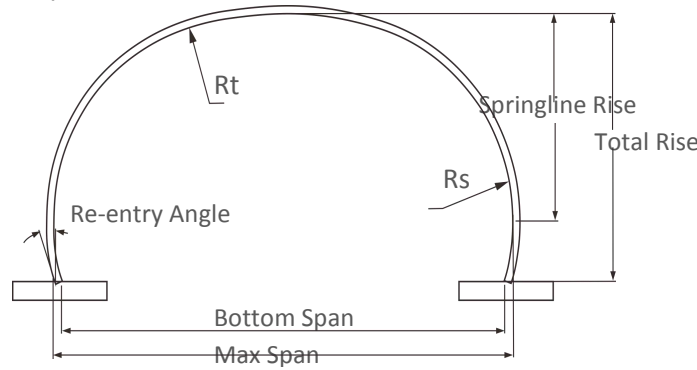

Max. Span mm	Botto m mm	Total Rise mm	Sprin gline mm	End Area m ²	Required S			Rt Top mm	Rs Side mm	Re-Entry Angle θ Degrees
					Top	Each Side	Total			
9190	9170	4585	4275	34.1	7	14.5	36	5730	4230	4.09
9165	8865	5380	4257	41.1	5	17.5	40	6530	4230	15.1
9420	9385	4690	4294	35.9	8	14.5	37	6030	4230	5.31
9340	9160	5290	4282	41.4	7	16.5	40	6330	4230	13.6
9720	9690	4795	4408	37.9	9	14.5	38	6130	4330	5.12
9760	9475	5595	4479	45.5	7	17.5	42	6530	4430	14.35
10085	10015	5070	4513	41.8	9	15.5	40	6730	4430	7.06
10060	9540	5790	4325	49.3	9	17.5	44	7630	4230	19.89
10400	10385	4655	4349	39.7	10	14.5	39	8230	4230	4.07
10485	10335	5275	4467	45.9	11	15.5	42	7430	4330	10.59
10400	10005	5990	4659	52	12	16.5	45	6330	4530	16.77
10690	10675	4770	4470	41.7	11	14.5	40	8130	4330	3.84
10700	10485	5355	4401	47.9	12	15.5	43	7930	4230	12.92
10680	10215	6075	4646	54.2	15	15.5	46	6430	4430	18.52
11000	10920	5030	4431	45.9	13	14.5	42	8330	4230	8.06
10985	10745	5440	4431	50	13	15.5	44	8230	4230	13.69
11000	10650	6385	4833	58.9	15	16.5	48	6630	4630	19.2
11225	11130	5140	4497	48	12	15.5	43	9330	4330	8.37
11300	10990	5680	4430	54.4	13	16.5	46	9430	4230	16.8
11240	10620	6495	4835	61.1	18	15.5	49	6630	4530	21.16
11580	11500	5230	4622	50.3	13	15.5	44	9330	4430	7.76

Deep corrugated structural plate box culverts

Type I: 381 x 140 mm corrugation profile

Size and layout details

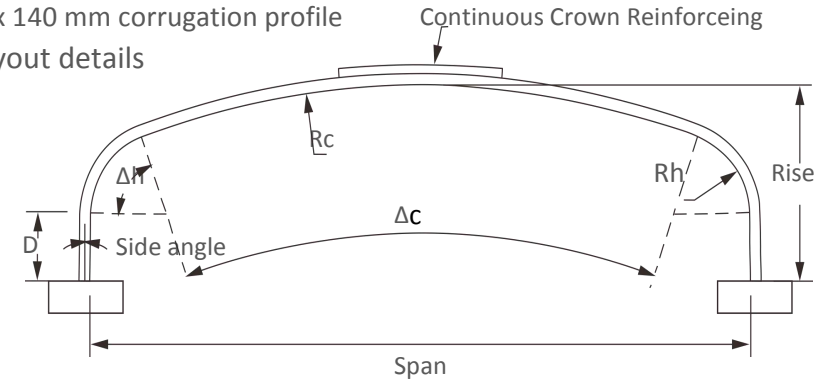

span mm	rise mm	End Area m ²	Crown Angle Δc degrees	Haunch Angle Δh degrees	Crown Radius Rc mm	Haunch Radius Rh mm	Side Length D mm	Side Angle degrees
3170	1180	3.12	7.35	72.36	8820	1016	407	14
3550	1420	4.33	9.97	75.04	8820	1016	559	10
3840	1465	4.94	12.59	77.72	8820	1016	509	6.31
3965	2210	7.35	9.97	72.36	8820	1016	1423	12.98
3865	1260	4.18	12.59	72.36	8820	1016	407	10.36
4105	1860	6.56	12.59	72.36	8820	1016	1017	11.67
4210	1310	4.76	15.21	72.36	8820	1016	407	9.05
4735	1960	8.16	17.83	72.36	8820	1016	1017	9.05
4550	1360	5.36	17.83	72.36	8820	1016	407	7.74
4890	1610	6.97	20.45	75.02	8820	1016	559	5.06
4860	2365	10.09	17.83	72.36	8820	1016	1423	9.05
5155	2420	11.06	20.45	72.36	8820	1016	1423	7.74
5215	1670	7.72	23.07	75.02	8820	1016	559	3.75
5360	2075	9.89	23.07	72.36	8820	1016	1017	6.43
5320	1440	6.62	23.57	69.69	8820	1016	419	8.53
5445	2480	12.07	23.07	72.36	8820	1016	1423	6.43
5655	1505	7.33	26.19	69.69	8820	1016	419	7.22
5955	2645	14.23	27.66	72.36	8820	1016	1473	3.81
6130	1495	7.83	30.28	72.36	8820	1016	254	2.5
6165	1900	10.33	30.28	72.36	8820	1016	660	2.5
6235	2715	15.36	30.28	72.36	8820	1016	1473	2.5